

84A2 SERIES (FIXED LOWER JAW)

Cam Type Sheet Metal Grippers | Ordering Information



Body Style Options

Description

- 84A2 Standard
- 84AT2 Sensor T-Slot

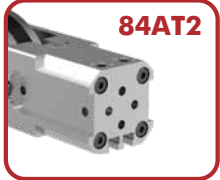
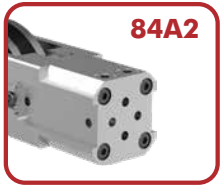

Porting Options

Description

- 1 (2) M5
- V (2) G1/8



Jaw Arrangement Options

Description

- 1 Double Upper, Straight Design
- 2 Double Upper, 90° Design
- 4 Single Upper, Left, Straight Design
- 6 Single Upper, Right, Straight Design
- 7 Double Upper, Straight Design, Drop Jaw
- 8 Double/Single Upper Extended Jaw
- 0 Double Upper, 45° Offset Design
- 9 Fixed Upper, Double Lower Jaws, 90° Design:
 [84A2/84AT2 (-)1/V 9] 45° Jaw Opening Angle Std.
 [84A2/84AT2 (X)1/V 9] 30° Jaw Opening Angle Std.

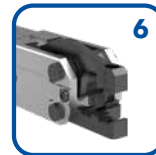

Jaw Opening Options

Description

- 72° Jaw Opening (Std.)
- X 30° Jaw Opening
- Y 45° Jaw Opening



Jaw Orientation Options (Option 8 Only)

Description

- "Blank" Double Jaw
- L Single Left Jaw
- R Single Right Jaw



Specifications	Unit	
Piston	mm	25
Actuation Time (open/close)	sec	<0,1
Air Consumption per Double Stroke at 6 bar	L	0,32

84A2 SERIES (FIXED LOWER JAW)

Cam Type Sheet Metal Grippers | Ordering Information

Gripper Teeth, Points and Crown Options (Upper and Lower)

Steel Teeth

- 00** None
- BA** Hardened - 8JZ-027-1
- BD** Hardened (Upper) - 8JZ-049-1



- BB** Soft Steel - 8JZ-028-1



High Temperature (84A2 Only)

- FF** Soft Steel - 8JZ-085-1



- EE** Soft Steel - 8JZ-092-1



Plastic Teeth*

- 00** None
 - KF** 90 Shore - 8JZ-045-2
- *Not suitable for High Temperature applications

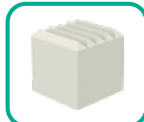

Steel Points

- 00** None
- PH** Hardened - 8JZ-029-1

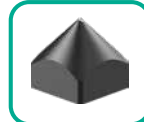

High Temperature (84A2 Only)

- PI** Soft Steel - 8JZ-074-1

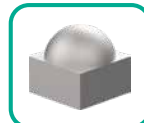

- RR** Soft Steel - 8JZ-088-1

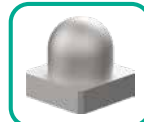

Crown Teeth

- 00** None
- SK** Hardened (Lower) - 8JZ-036-2
- SQ** Hardened (Lower) - 8JZ-051-1
- SL** Hardened (Upper) - 8JZ-037-1
- SM** Hardened (Upper) - 8JZ-038-1
- SN** Hardened (Upper) - 8JZ-039-1
- SP** Hardened (Upper) - 8JZ-040-1



High Temperature (84A2 Only)

- DD** Soft Steel - 8JZ-087-1 (Lower)



- LL** Soft Steel - 8JZ-086-1 (Lower)

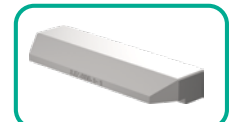

Shims for gripper teeth available
Order Separately **8SB-039-1**
Dimensions: 10 x 10 x 1 mm



Sensor Options (not suitable for High Temperature applications)

Description

- 00** None
- D4*** Part Present Sensor 3mm Sensing Distance, 2m Cable - 8EA-075-2
- D5** Double Sheet Control Sensor, M12x1 Plug - 8EA-087-1
- D7*** Part Present Sensor, 3mm Sensing Distance, M12x1 Plug - 8EA-075-3
- D8** 2X Position Sensor - 8EA-109-1 (84AT2 Models Only)
- GP*** 1X **D4** + 1X **D5**
- GQ*** 1X **D5** + 1X **D7**
- GK** 2X **D5** (not for 84AT2 Models)

*For Jaw Arrangements Options 1, 2, 7, 8, 9 only.

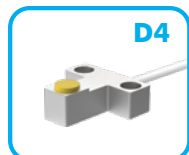

Cable support for **D4** Sensor. Order Separately **8MA-149-1**
Mounted on lower side of gripper (for 84A2-11, 84A2-V1,
84A2-18, 84A2-V8 only) (not for 84AT2 Models)

Cover for Sensing Systems **D5, GP, GQ, GK**
Order Separately **82ZB-185-1**

Mounting Options

Description

- 0** None
- I** Ø20mm Rear Rod 8MA-165-1
- J** Ø25mm Rear Rod 8MA-166-1
- Z** Ø1.00" Rear Rod 8MA-168-1
- L** Ø20mm Apple Core GT-20M-84A2-L-R
- M** Ø32mm Rear Ball GT-32B-84A2- L-R
- N** Ø32mm Flanged Ball GT-32B-84A2- B
- Q** Guards 8MH-054-1 (For Jaw Arrangements Options 1, 4, 6 only)
- V** Rear Flange 8MA-147-1
- W** On-Body Swivel Ball 82ZB-025-2

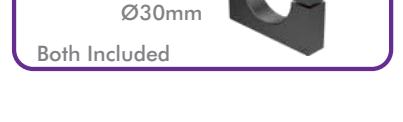

84A2..1 SERIES (FIXED LOWER JAW)

Cam Type Sheet Metal Grippers | Dimensions and Technical Specifications

84A2.11

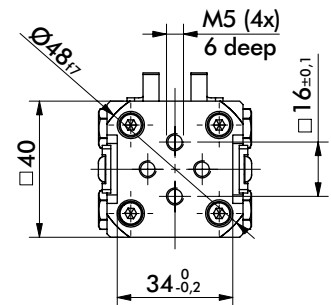
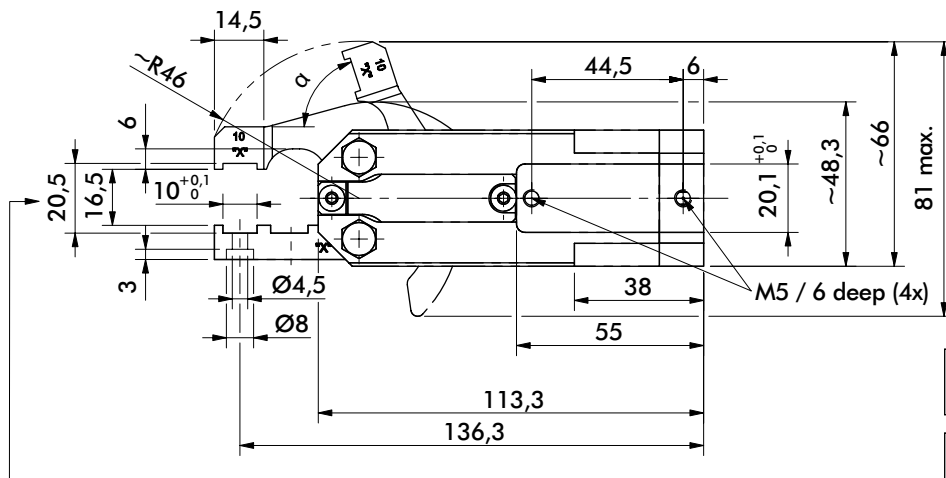
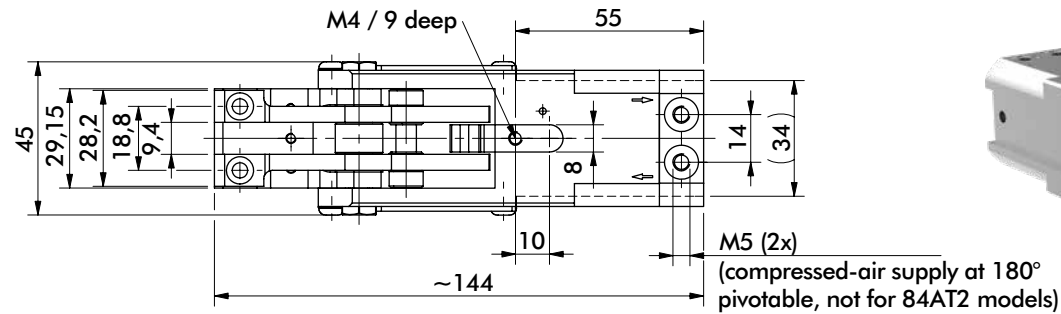

Medium air, min. 3 bar, max. 6 bar.
Operation with oil-free air is permissible.

NOTE! Any extension of the moveable or fixed gripper jaws as well as the additional attachment of weights will void warranty.

Addition of gripper teeth height and thickness of the clamped plate must be 20,5 mm.
It might be necessary to use shim plates or to grind off the gripper teeth.

84A2.V1

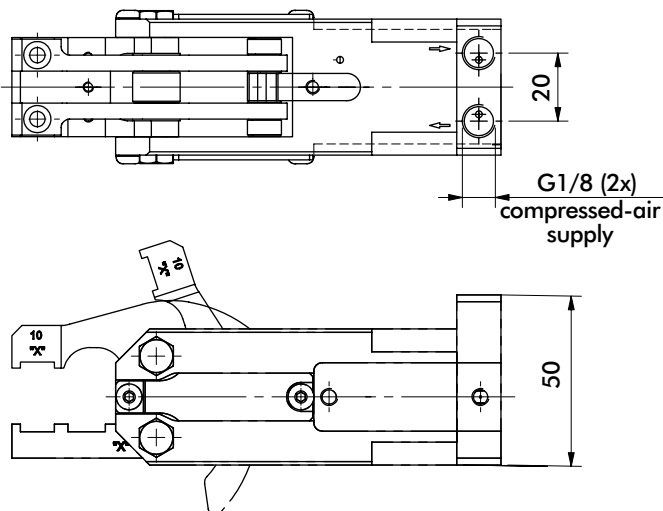

84AT2..1

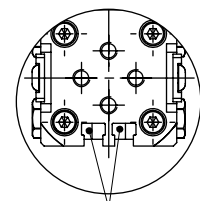
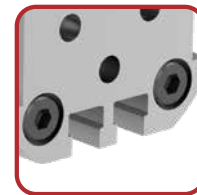

T-groove for sensor

Model	Opening Angle α	Clamping force at 6 bar ~N [lbs]	Weight Kg [lbs]
84A2..1/84AT2..1			
-	72°	920 [207]	0,6 [1.32]
X	30°		
Y	45°		

84A2..2 SERIES (FIXED LOWER JAW)

Cam Type Sheet Metal Grippers | Dimensions and Technical Specifications

84A2.12

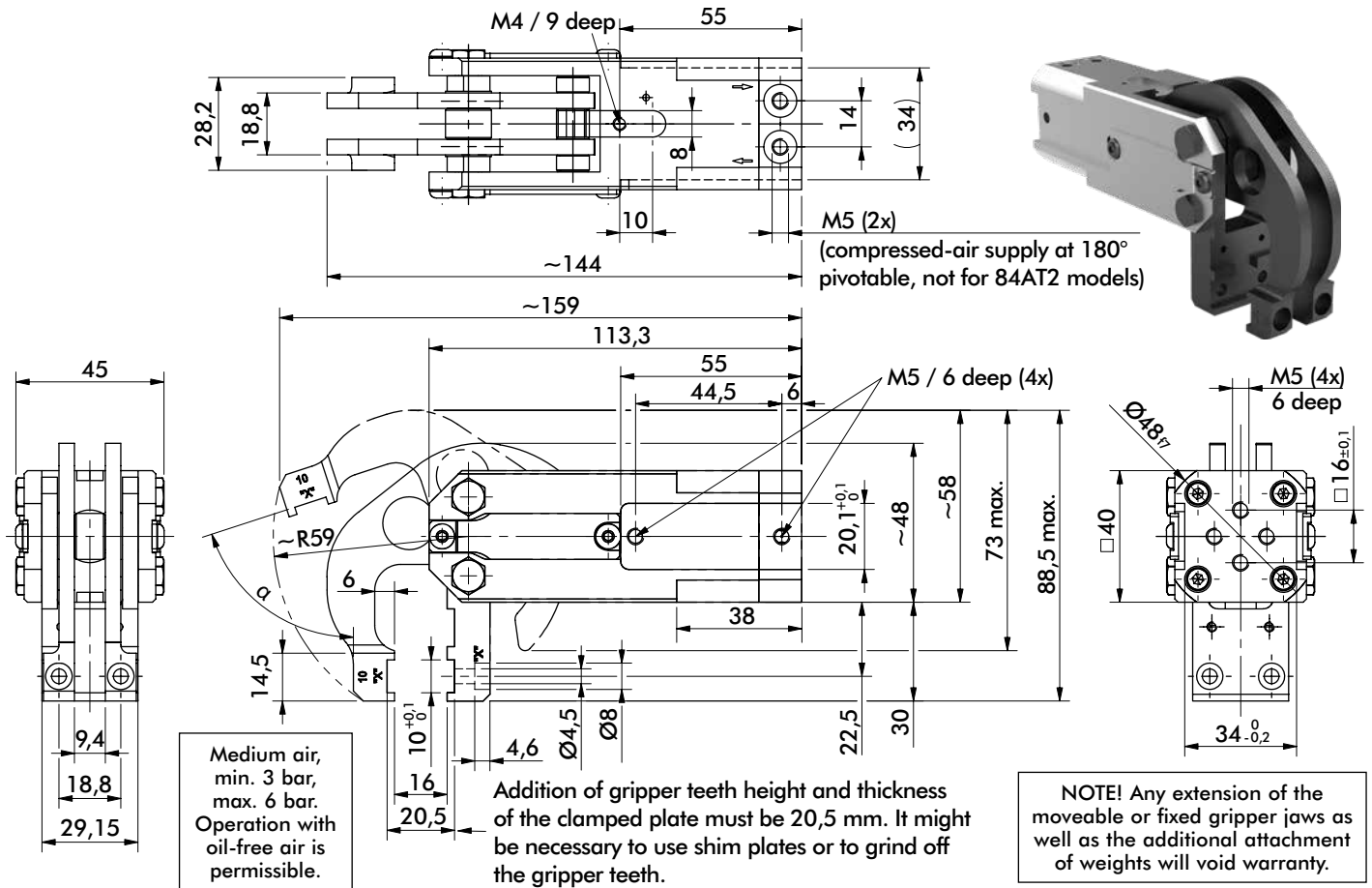

84A2.V2

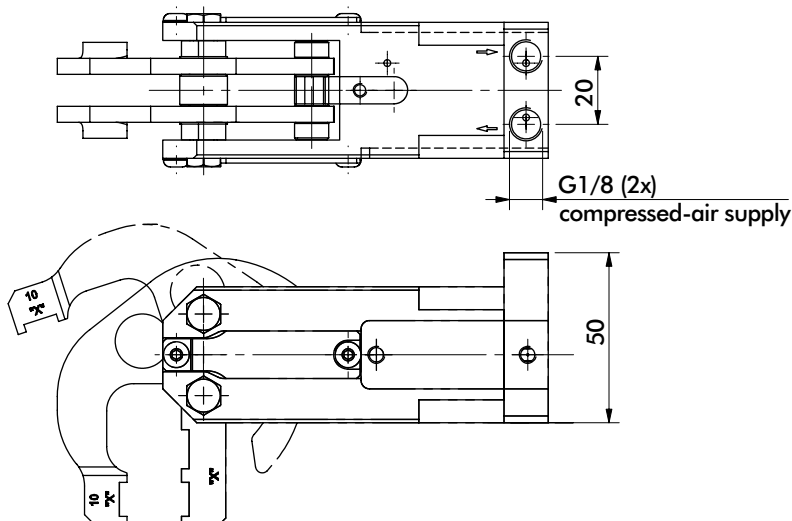

84AT2..2

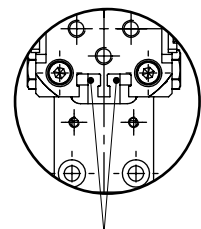
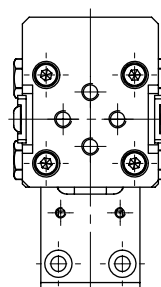
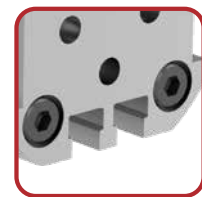

T-groove for sensor

Model 84A2..2/84AT2..2	Opening Angle α	Clamping force at 6 bar ~N [lbs]	Weight Kg [lbs]
-	72°		
X	30°	575 [129]	0,65 [1.43]
Y	45°		

84A2..4 SERIES (FIXED LOWER JAW)

Cam Type Sheet Metal Grippers | Dimensions and Technical Specifications

84A2.14

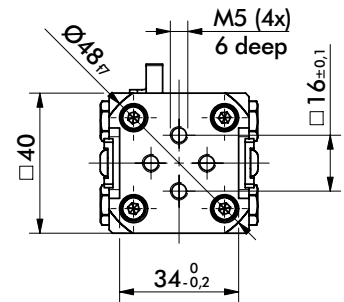
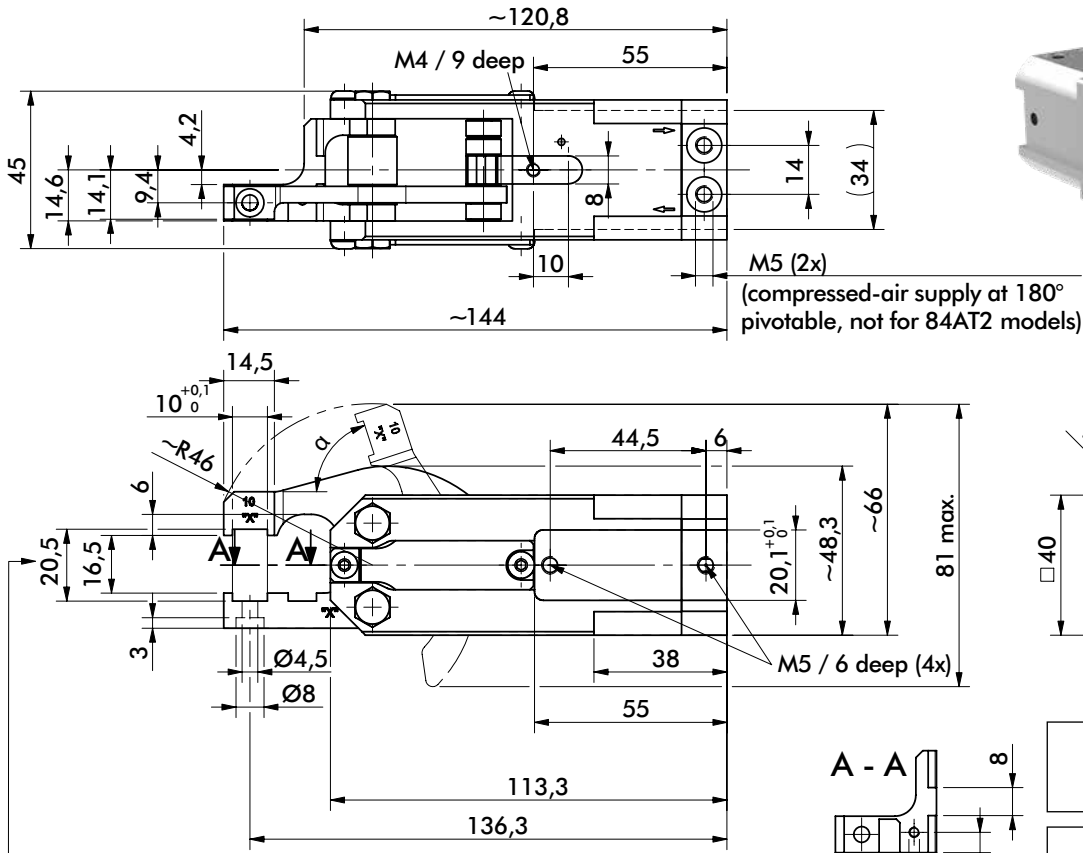

Medium air, min. 3 bar, max. 6 bar. Operation with oil-free air is permissible.

NOTE! Any extension of the moveable or fixed gripper jaws as well as the additional attachment of weights will void warranty.

Addition of gripper teeth height and thickness of the clamped plate must be 20,5 mm. It might be necessary to use shim plates or to grind off the gripper teeth.

84A2.V4

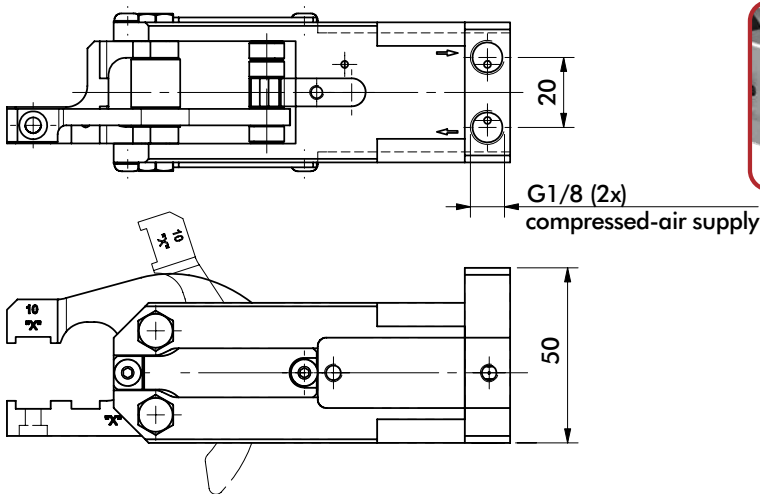

84AT2..4

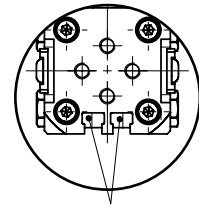
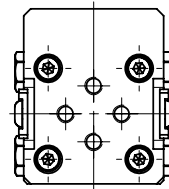
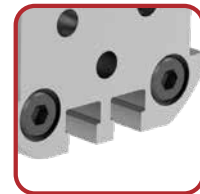

T-groove for sensor

Model 84A2..4/84AT2..4	Opening Angle α	Clamping force at 6 bar ~N [lbs]	Weight Kg [lbs]
-	72°	920 [207]	0,5 [1.1]
X	30°		
Y	45°		

84A2..6 SERIES (FIXED LOWER JAW)

Cam Type Sheet Metal Grippers | Dimensions and Technical Specifications

84A2.16

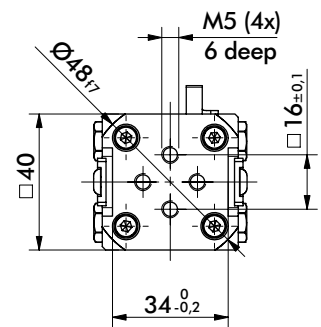
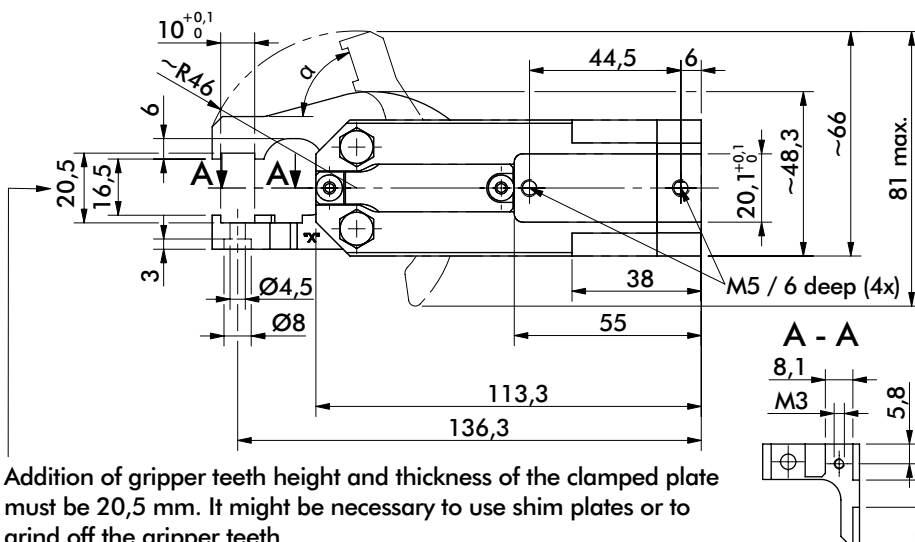
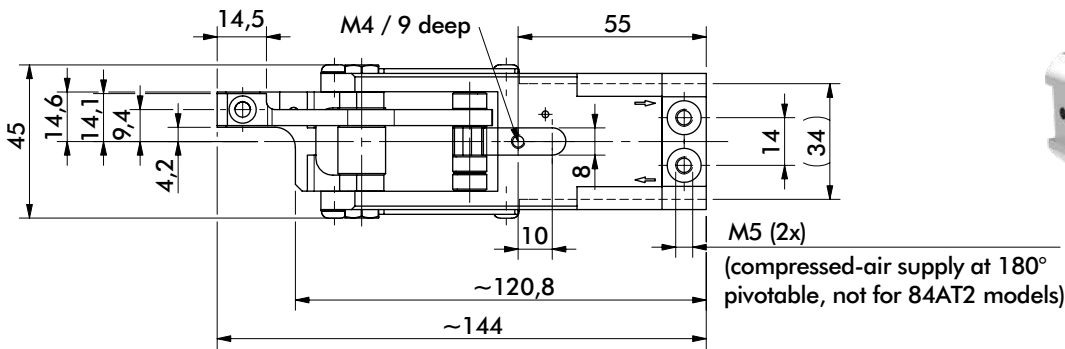

Medium air,
min. 3 bar,
max. 6 bar.
Operation with
oil-free air is
permissible.

NOTE! Any extension
of the moveable or
fixed gripper jaws
as well as the additional
attachment of weights
will void warranty.

Addition of gripper teeth height and thickness of the clamped plate must be 20,5 mm. It might be necessary to use shim plates or to grind off the gripper teeth.

84A2.V6

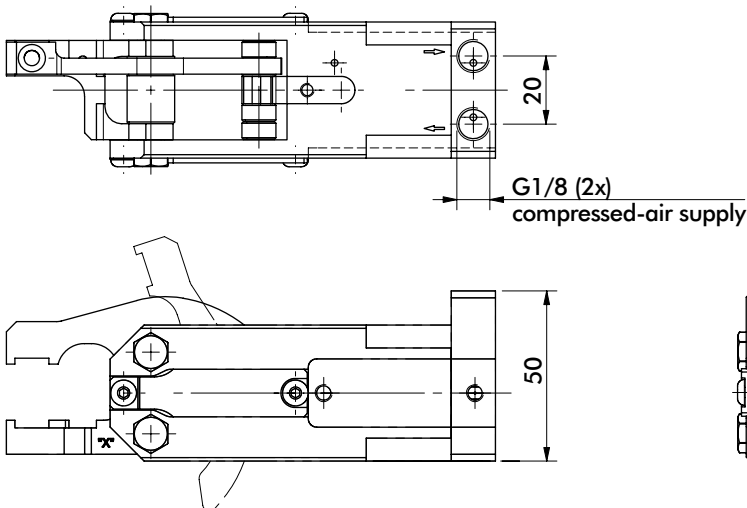

84AT2..6

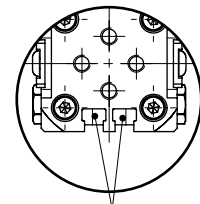
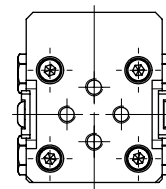
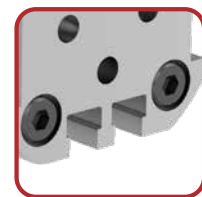

T-groove for sensor

Model 84A2..6/84AT2..6	Opening Angle α	Clamping force at 6 bar ~N [lbs]	Weight Kg [lbs]
-	72°		
X	30°	920 [207]	0,5 [1.1]
Y	45°		

84A2..7 SERIES (FIXED LOWER JAW)

Cam Type Sheet Metal Grippers | Dimensions and Technical Specifications

84A2.17

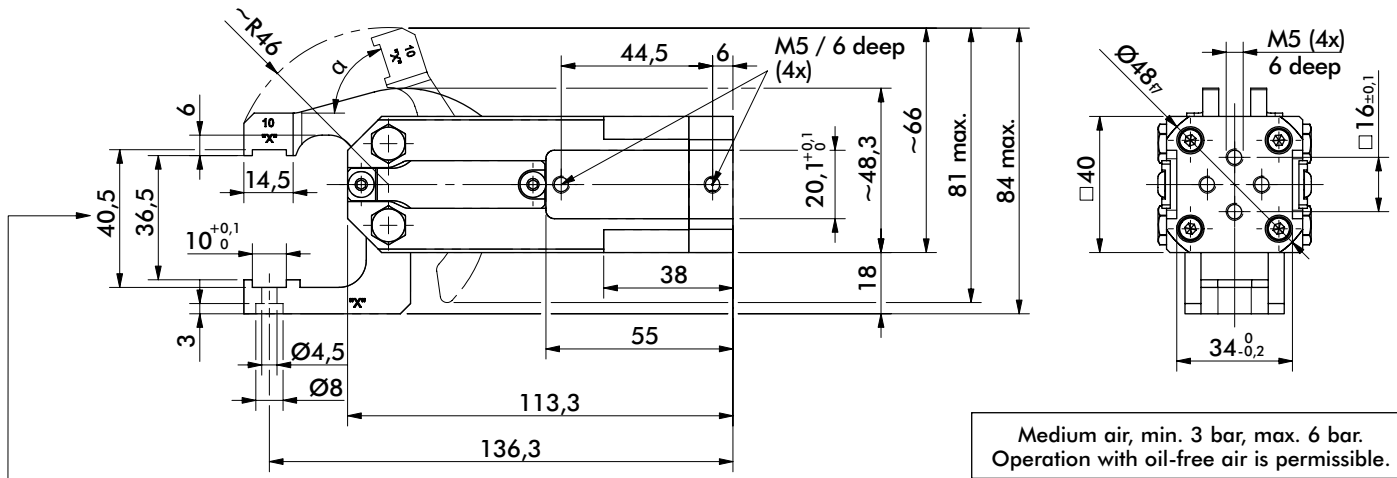
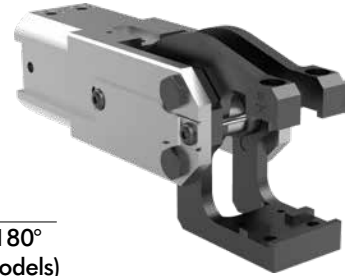
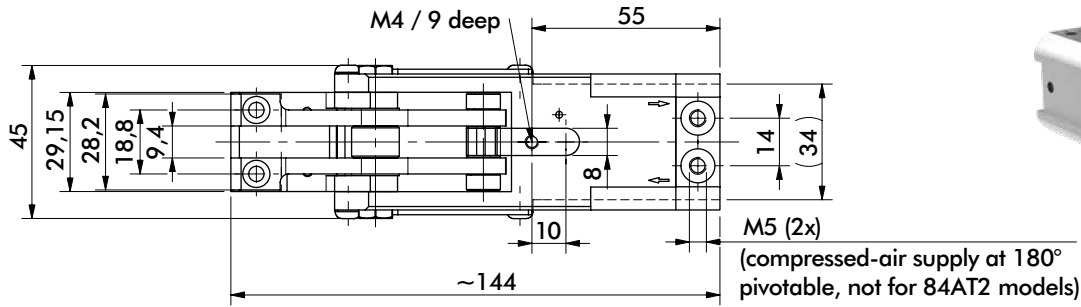

Addition of gripper teeth height and thickness of the clamped plate must be 40,5 mm. It might be necessary to use shim plates or to grind off the gripper teeth.

NOTE! Any extension of the moveable or fixed gripper jaws as well as the additional attachment of weights will void warranty.

84A2.V7

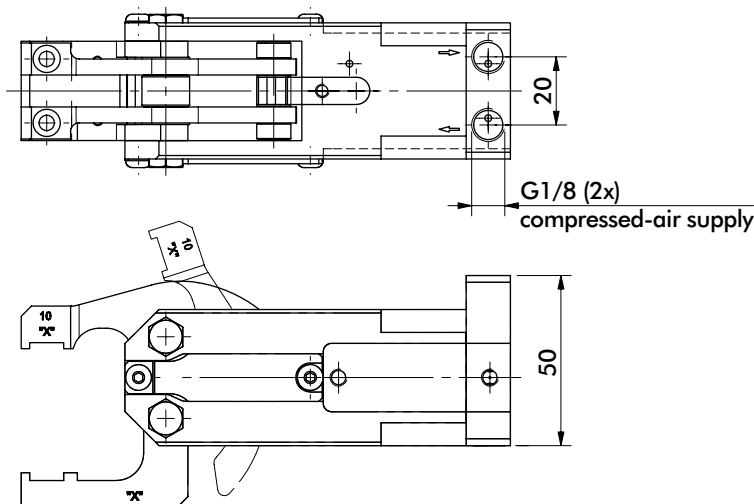

84AT2..7

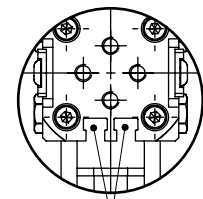
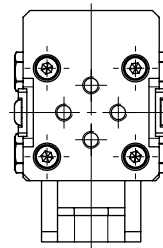
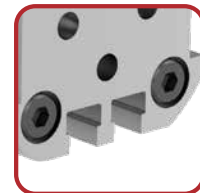
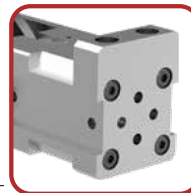

T-groove for sensor

Model 84A2..7/84AT2..7	Opening Angle α	Clamping force at 6 bar ~N [lbs]	Weight Kg [lbs]
-	72°	920 [207]	0,6 [1.32]
X	30°		
Y	45°		

84A2..8 SERIES (FIXED LOWER JAW)

Cam Type Sheet Metal Grippers | Dimensions and Technical Specifications

84A2.18

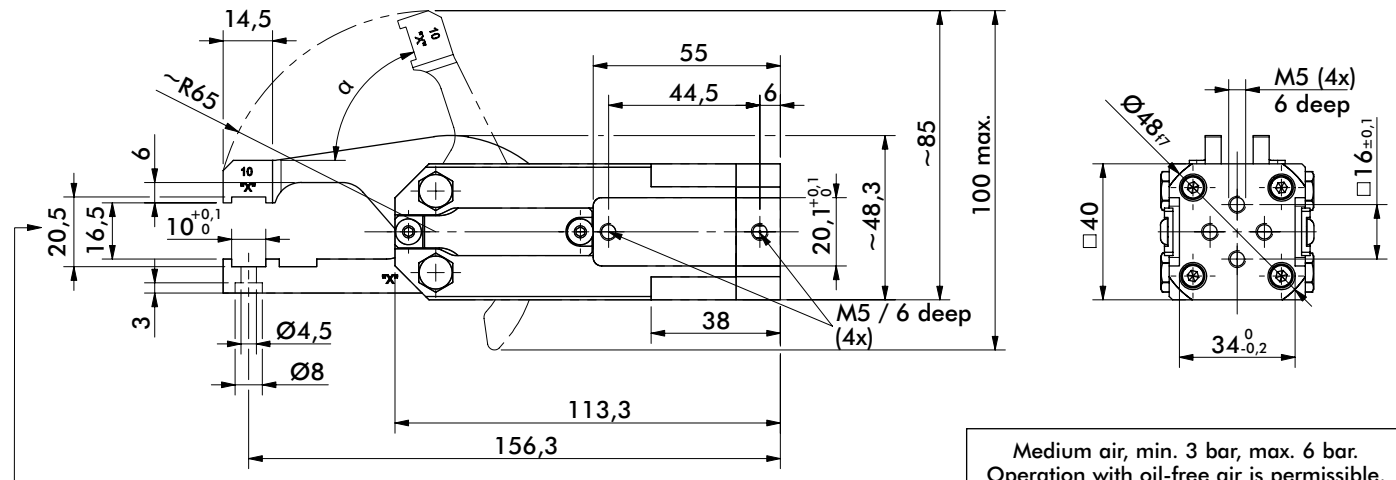
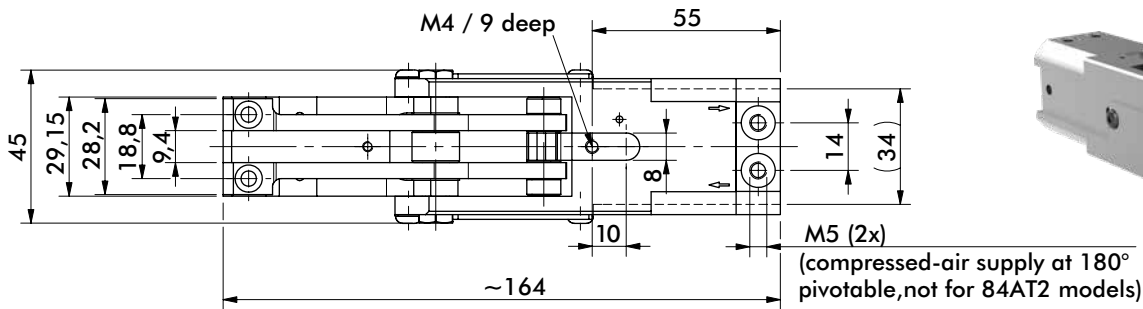

Medium air, min. 3 bar, max. 6 bar.
Operation with oil-free air is permissible.

Addition of gripper teeth height and thickness of the clamped plate must be 20,5 mm. It might be necessary to use shim plates or to grind off the gripper teeth.

NOTE! Any extension of the moveable or fixed gripper jaws as well as the additional attachment of weights will void warranty.

84A2.V8

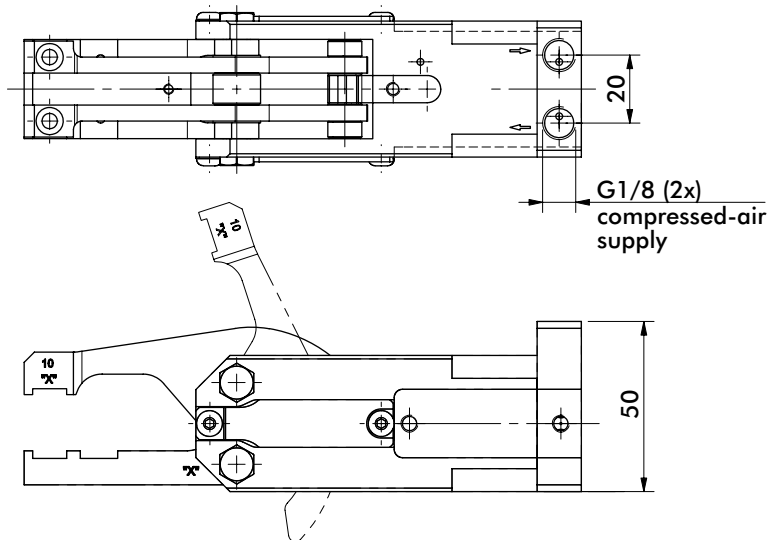

84AT2..8

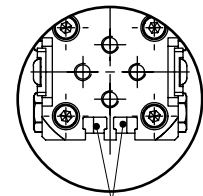
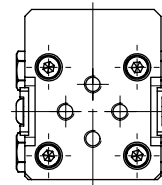
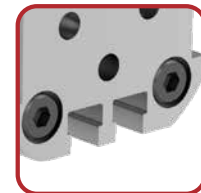

T-groove for sensor

Model 84A2..8/84AT2..8	Opening Angle α	Clamping force at 6 bar ~N [lbs]	Weight Kg [lbs]
-	72°	560 [126]	0,65 [1.43]
X	30°		
Y	45°		

84A2...8 SERIES (FIXED LOWER JAW)

Cam Type Sheet Metal Grippers | Dimensions and Technical Specifications

84A2..18

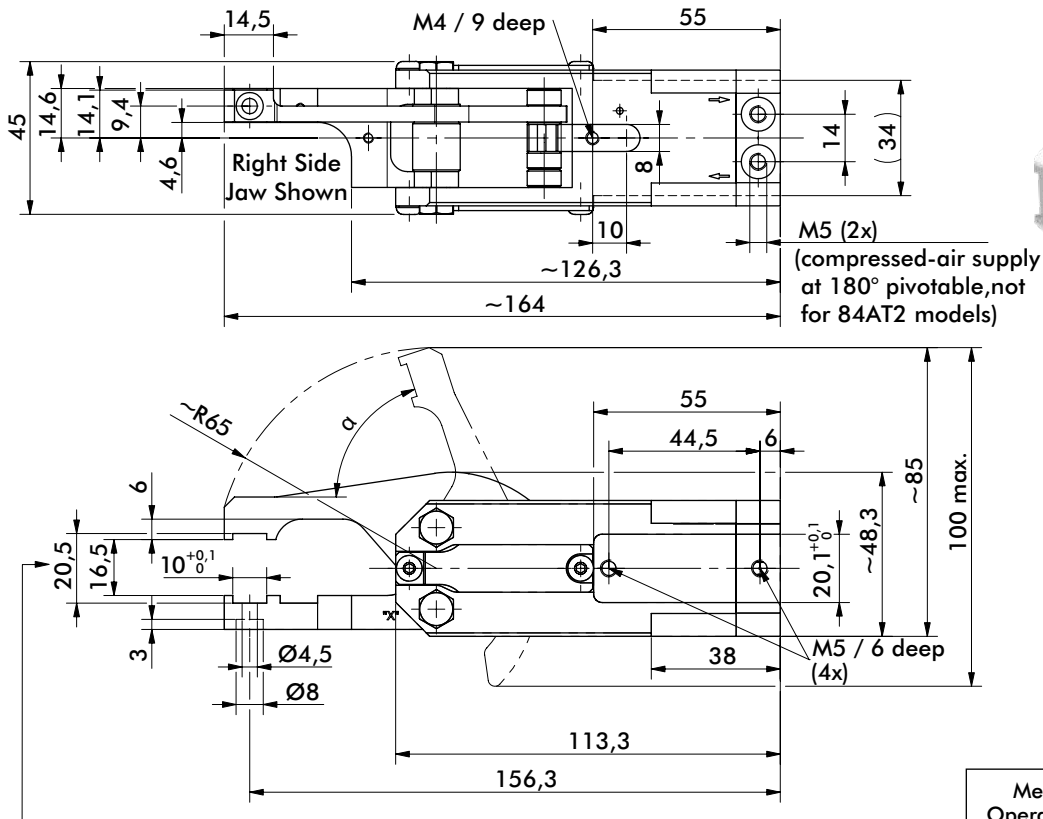

Medium air, min. 3 bar, max. 6 bar.
Operation with oil-free air is permissible.

NOTE! Any extension of the moveable or fixed gripper jaws as well as the additional attachment of weights will void warranty.

Addition of gripper teeth height and thickness of the clamped plate must be 20,5 mm. It might be necessary to use shim plates or to grind off the gripper teeth.

84A2..V8

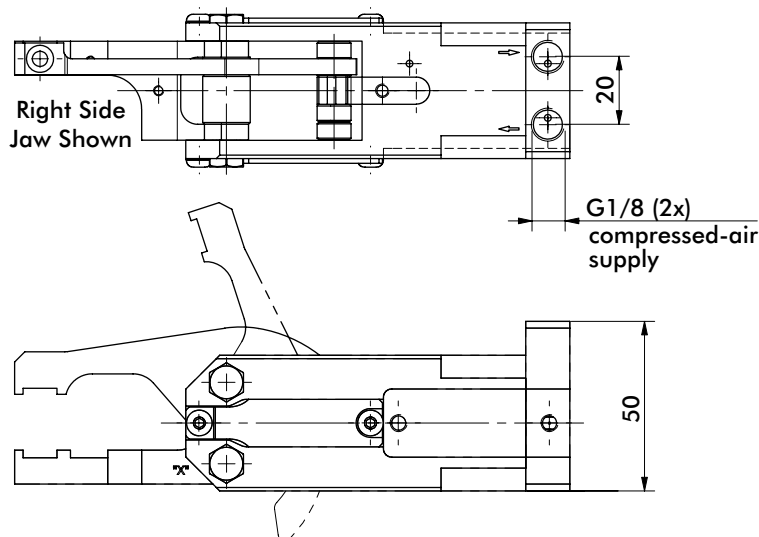

84AT2...8

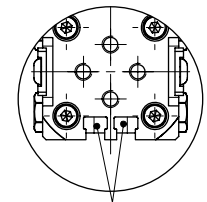
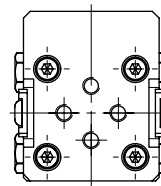
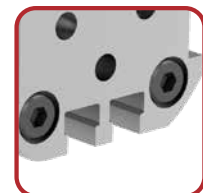
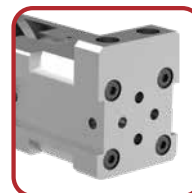

T-groove for sensor

Model 84A2...8/84AT2...8	Opening Angle α	Clamping force at 6 bar ~N [lbs]	Weight Kg [lbs]
-	72°		
Y	30°	560 [126]	0,65 [1.43]
X	45°		

84A2..0 SERIES (FIXED LOWER JAW)

Cam Type Sheet Metal Grippers | Dimensions and Technical Specifications

84A2.10

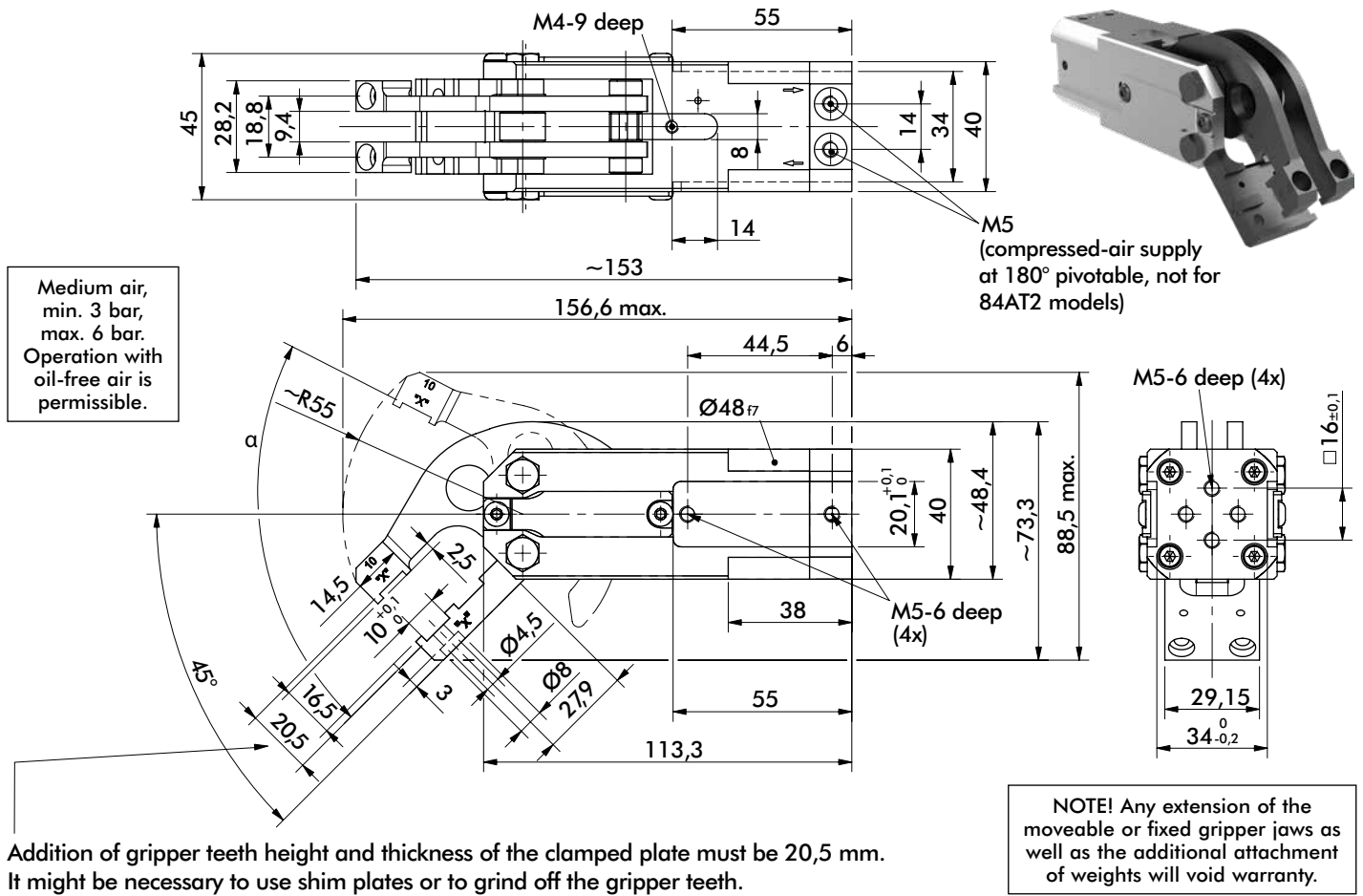

84A2.V0

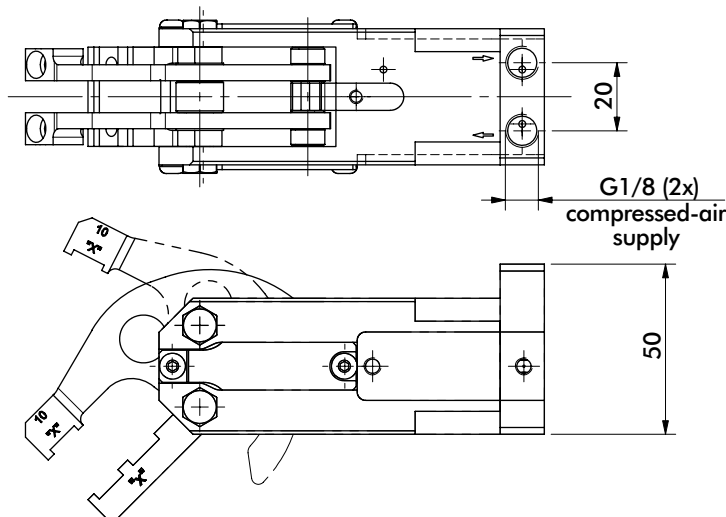

84AT2..0

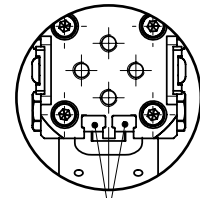
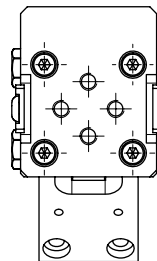
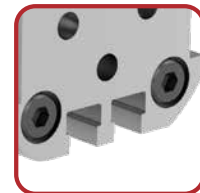

T-groove for sensor

Model 84A2..0/84AT2..0	Opening Angle α	Clamping force at 6 bar ~N [lbs]	Weight Kg [lbs]
-	72°	600 [135]	0,65 [1.43]
X	30°		
Y	45°		

84A2 SERIES (MOVEABLE LOWER JAWS)

Cam Type Sheet Metal Grippers | Ordering Information

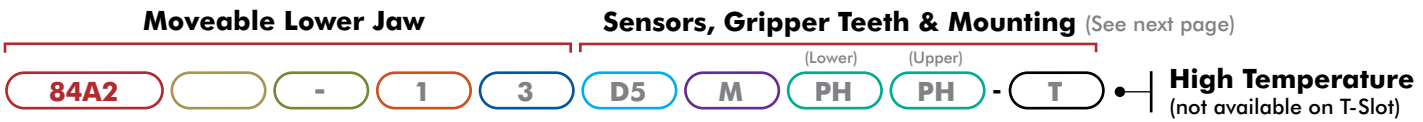

Body Style Options

Description

- 84A2 Standard
- 84AT2 Sensor T-Slot

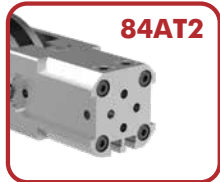

Porting Options

Description

- 1 (2) M5
- V (2) G1/8



Jaw Arrangement Options

Description

- 3 Double Symmetrical, Straight Design
- 5 Single Symmetrical, Straight Design



Jaw Orientation Options

Description

- "Blank" Double (Jaw Arrangement Options 3 only)
- L Single Left (Jaw Arrangement Options 5 only)
- R Single Right (Jaw Arrangement Options 5 only)



Jaw Opening Options

Description

- 72° Jaw Opening (Symmetrical)
- X 30° Jaw Opening (Symmetrical)
- Y 45° Jaw Opening (Symmetrical)
- R 72° Upper/15° Lower Jaw
- T 45° Upper/15° Lower Jaw

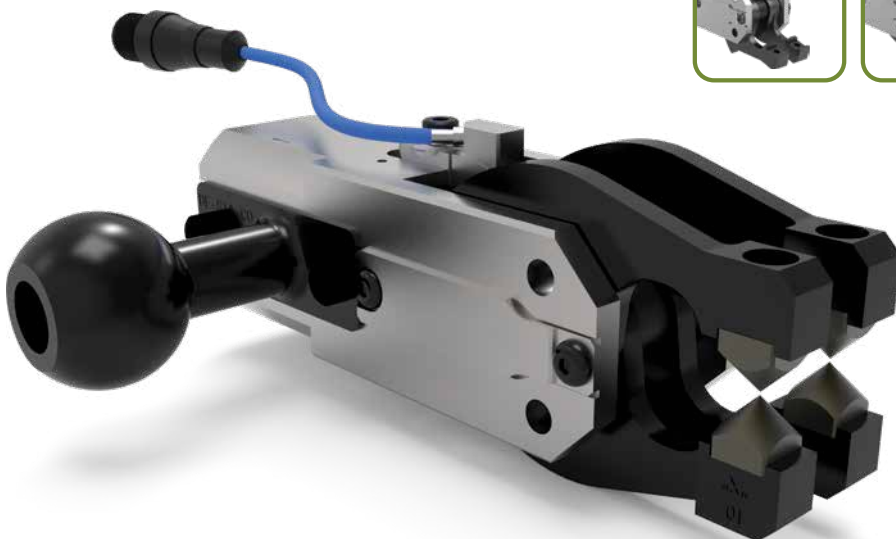
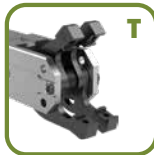

Specifications	Unit	
Piston	mm	25
Actuation Time (open/close)	sec	<0,1
Air Consumption per Double Stroke at 6 bar	L	0,32

84A2 SERIES (MOVEABLE LOWER JAWS)

Cam Type Sheet Metal Grippers | Ordering Information

Gripper Teeth, Points and Crown Options (Upper and Lower)

Steel Teeth

- 00** None
- BA** Hardened - 8JZ-027-1
- BD** Hardened (Upper) - 8JZ-049-1

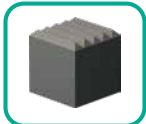

- BB** Soft Steel - 8JZ-028-1



High Temperature (84A2 Only)

- FF** Soft Steel - 8JZ-085-1



- EE** Soft Steel - 8JZ-092-1



Plastic Teeth*

- 00** None
 - KF** 90 Shore - 8JZ-045-2
- *Not suitable for High Temperature applications

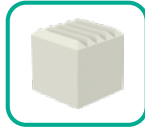

Steel Points

- 00** None
- PH** Hardened - 8JZ-029-1

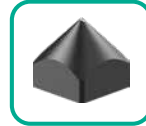

High Temperature (84A2 Only)

- PI** Soft Steel - 8JZ-074-1

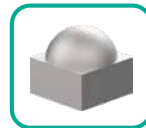

- RR** Soft Steel - 8JZ-088-1

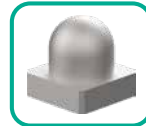

Crown Teeth

- 00** None
- SK** Hardened (Lower) - 8JZ-036-2
- SQ** Hardened (Lower) - 8JZ-051-1
- SL** Hardened (Upper) - 8JZ-037-1
- SM** Hardened (Upper) - 8JZ-038-1
- SN** Hardened (Upper) - 8JZ-039-1
- SP** Hardened (Upper) - 8JZ-040-1



High Temperature (84A2 Only)

- DD** Soft Steel - 8JZ-087-1 (Lower)



- LL** Soft Steel - 8JZ-086-1 (Lower)

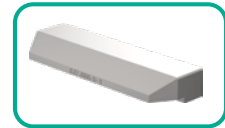

Shims for gripper teeth available
Order Separately - **8SB-039-1**
Dimensions: 10 x 10 x 1 mm



Mounting Options

Description

- | | |
|--|---|
| 0 None | M Ø32mm Rear Ball
GT-32B-84A2- L-R |
| I Ø20mm Rear Rod
8MA-165-1 | N Ø32mm Flanged Ball
GT-32B-84A2- B |
| J Ø25mm Rear Rod
8MA-166-1 | V Rear Flange
8MA-147-1 |
| Z Ø1.00" Rear Rod
8MA-168-1 | W On-Body Swivel Ball
82ZB-025-2 |
| L Ø20mm Apple Core
GT-20M-84A2-L-R | |

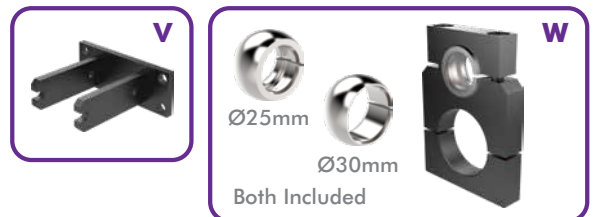

Sensor Options (not suitable for High Temperature applications)

Description

- 00** None
- D5** Double Sheet Control Sensor, M12x1 Plug - 8EA-087-1
- D8** 2X Position Sensor - 8EA-109-1 (84AT2 Models Only)
- GK** 2X **D5** (not for 84AT2 Models)



Cover for Sensing Systems **D5, GK**
Order Separately **82ZB-185-1**

84A2..3 SERIES (DOUBLE SYMMETRICAL MOVEABLE JAWS)

Cam Type Sheet Metal Grippers | Dimensions and Technical Specifications

84A2.13

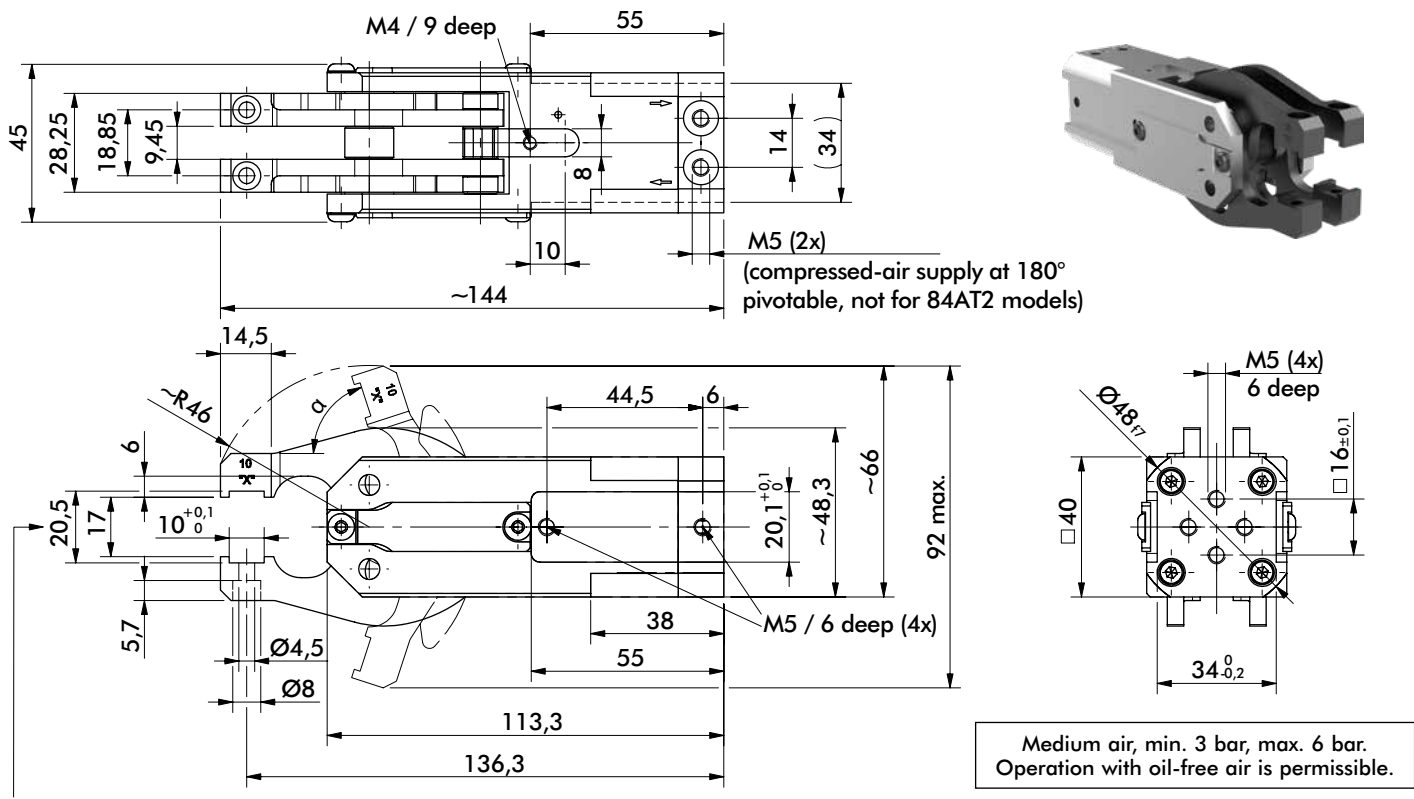

Addition of gripper teeth height and thickness of the clamped plate must be 20,5 mm. It might be necessary to use shim plates or to grind off the gripper teeth.

NOTE! Any extension of the moveable or fixed gripper jaws as well as the additional attachment of weights will void warranty.

84A2.V3

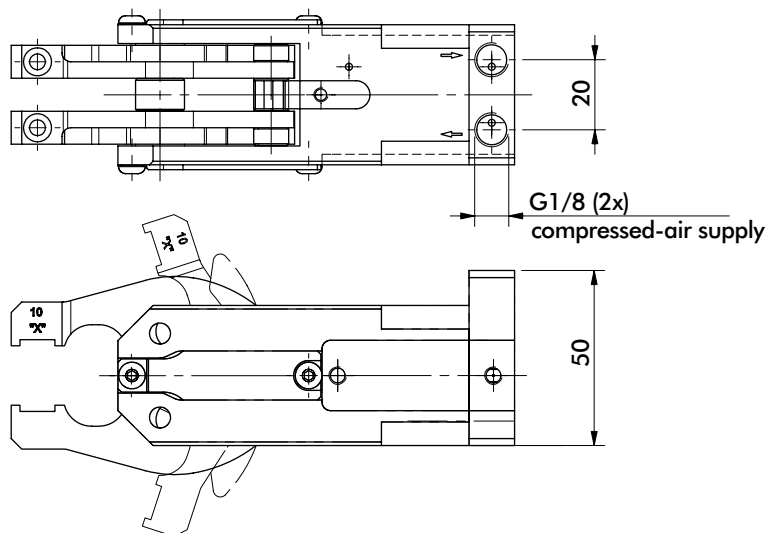

84AT2..3

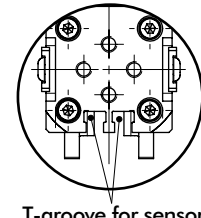
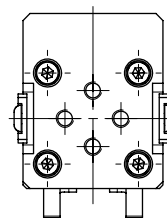
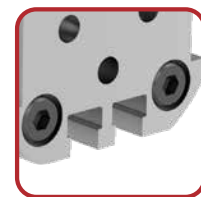

Model 84A2..3/84AT2..3	Opening Angle α Symmetrical	Clamping force at 6 bar ~N [lbs]	Weight Kg [lbs]
-	72°	475 [107]	0,6 [1.32]
X	30°		
Y	45°		

84A2...5 SERIES (SINGLE SYMMETRICAL MOVEABLE JAWS)

Cam Type Sheet Metal Grippers | Dimensions and Technical Specifications

84A2..15

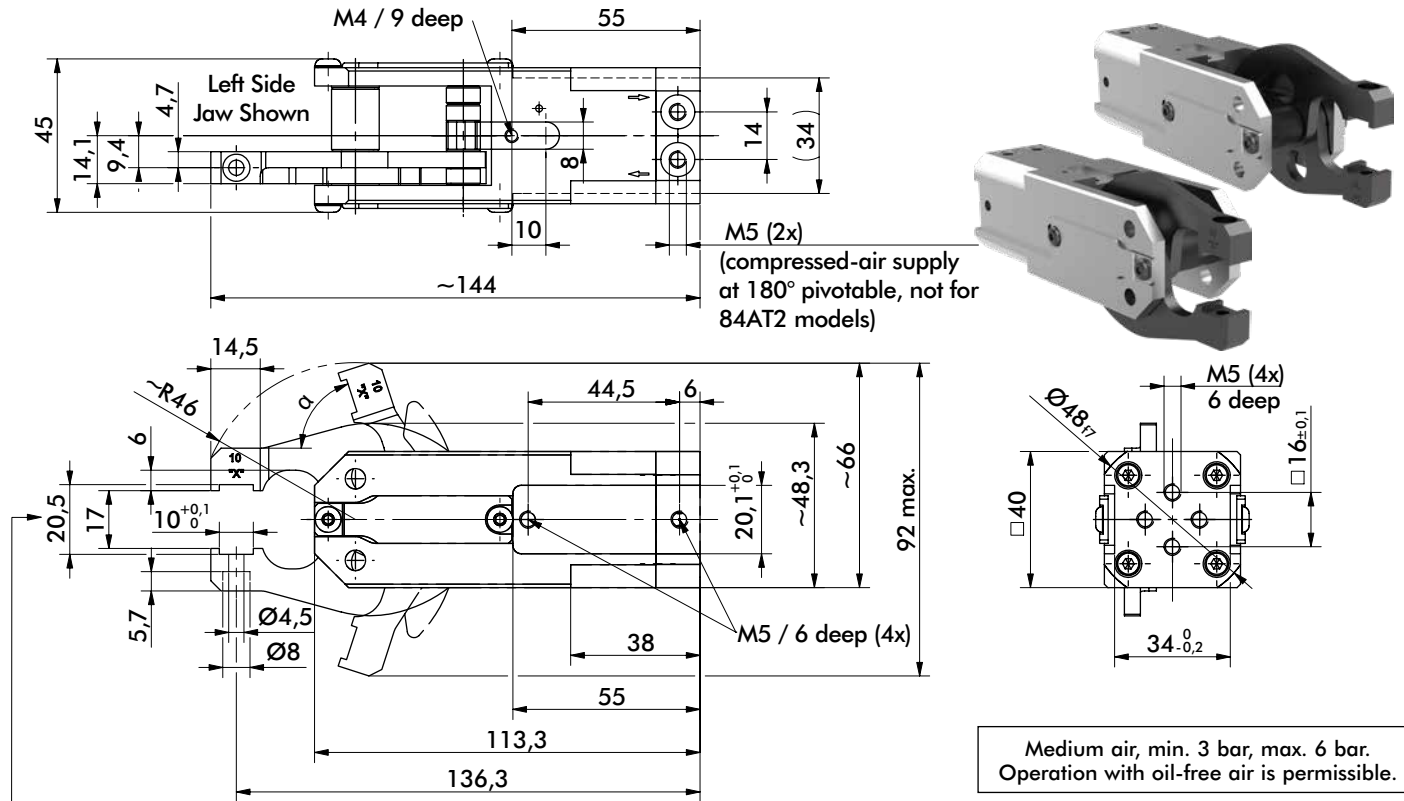

Addition of gripper teeth height and thickness of the clamped plate must be 20,5 mm. It might be necessary to use shim plates or to grind off the gripper teeth.

NOTE! Any extension of the moveable or fixed gripper jaws as well as the additional attachment of weights will void warranty.

84A2..V5

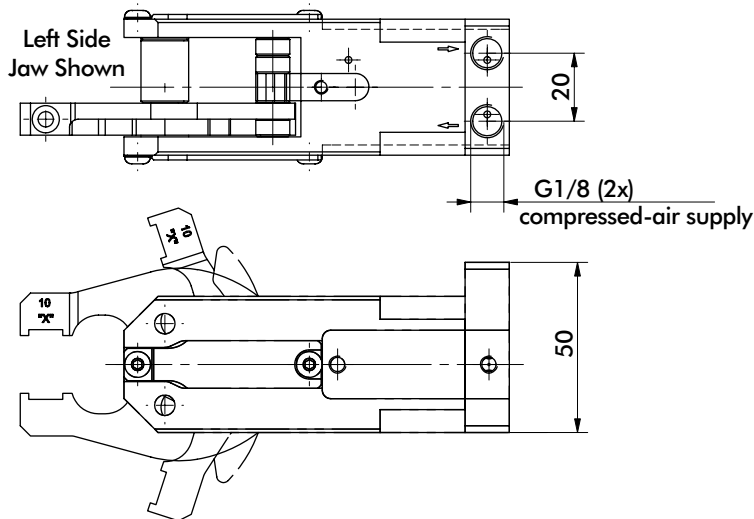

84AT2...5

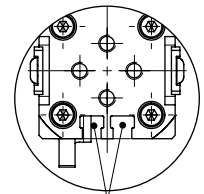
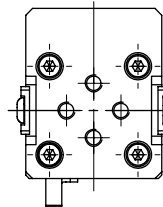
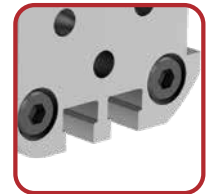

T-groove for sensor

Model 84A2...5/84AT2...5	Opening Angle α Symmetrical	Clamping force at 6 bar ~N [lbs]	Weight Kg [lbs]
-	72°		
X	30°	475 [107]	0,47 [1.04]
Y	45°		

84A2...5 SERIES (SINGLE 15° MOVEABLE LOWER JAW)

Cam Type Sheet Metal Grippers | Dimensions and Technical Specifications

84A2..15

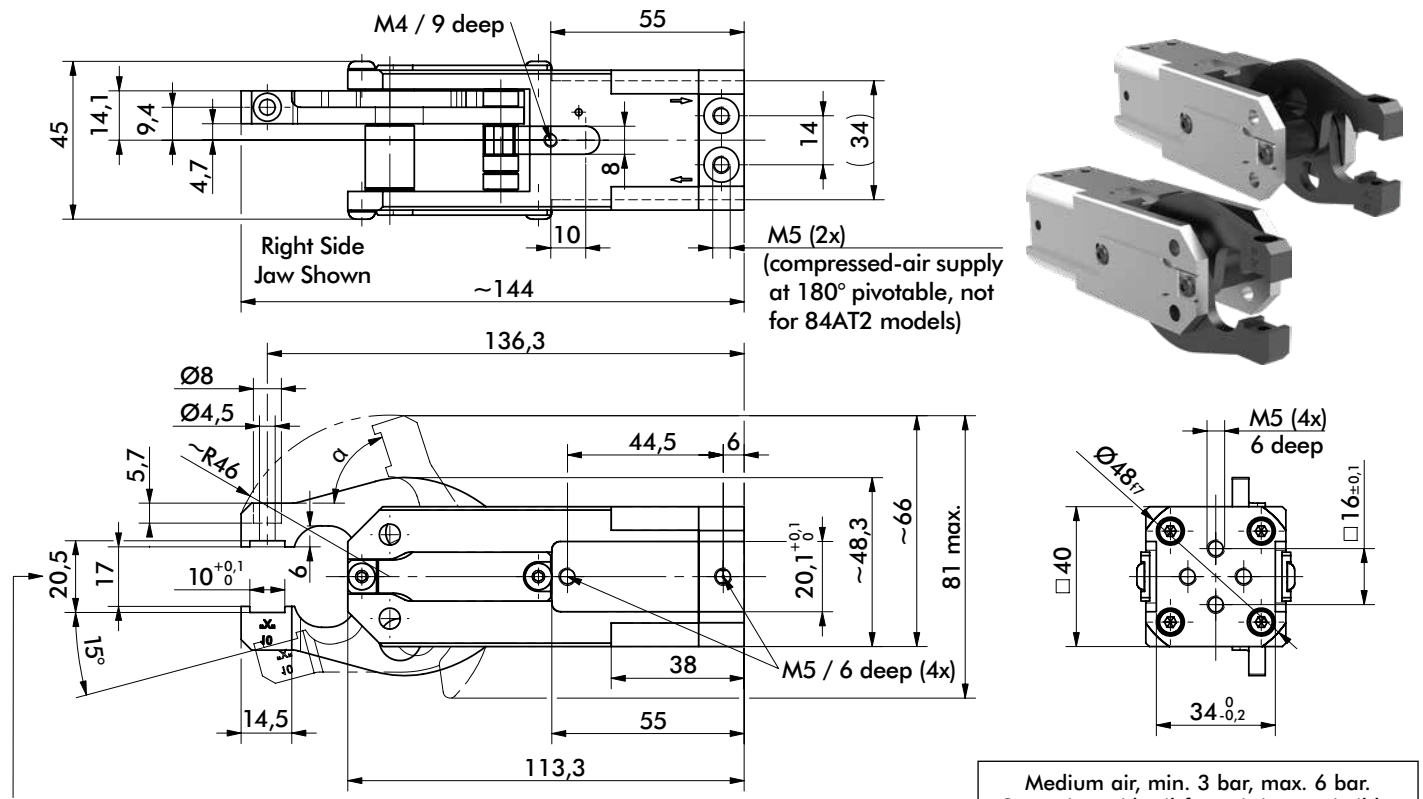

Medium air, min. 3 bar, max. 6 bar.
Operation with oil-free air is permissible.

Addition of gripper teeth height and thickness of the clamped plate must be 20,5 mm. It might be necessary to use shim plates or to grind off the gripper teeth.

NOTE! Any extension of the moveable or fixed gripper jaws as well as the additional attachment of weights will void warranty.

84A2..V5

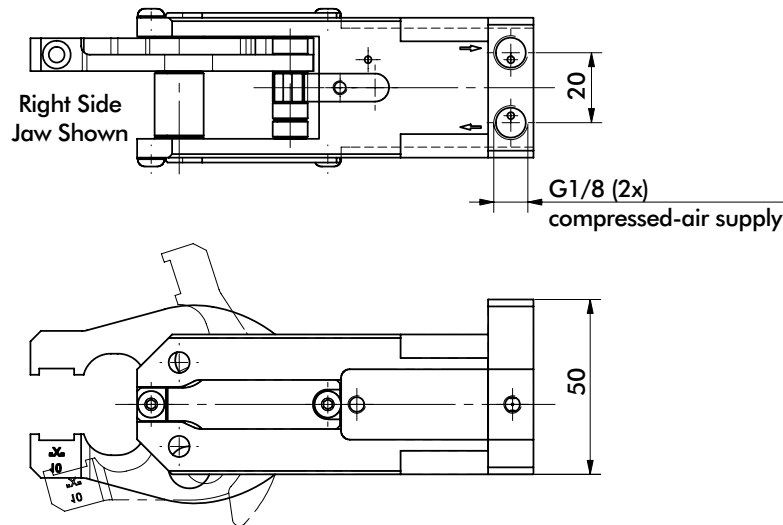

84AT2...5

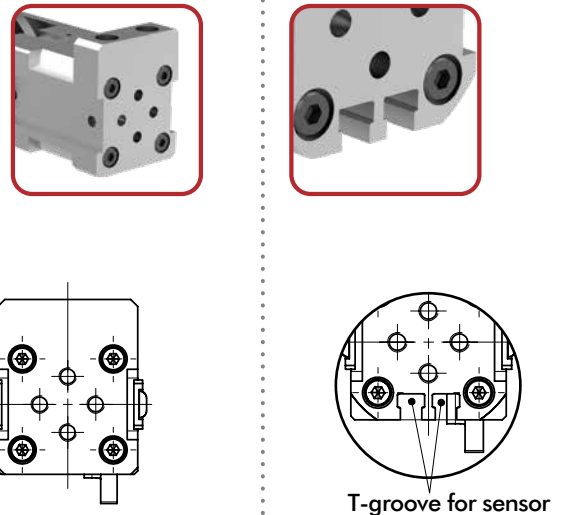

Model	Opening Angle α Upper/Lower	Clamping force at 6 bar ~N [lbs]	Weight Kg [lbs]
84A2...5/84AT2...5			
R	72°/15°	475 [107]	0,47 [1.04]
T	45°/15		

84A2 SERIES ACCESSORIES

Cam Type Sheet Metal Grippers | Dimensions and Ordering Information

Steel Teeth

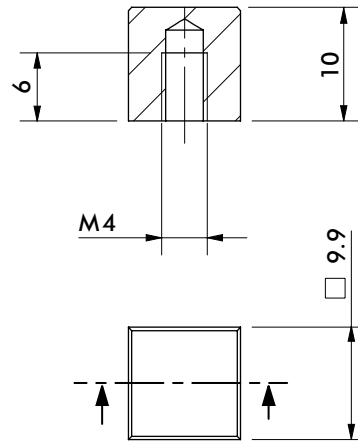
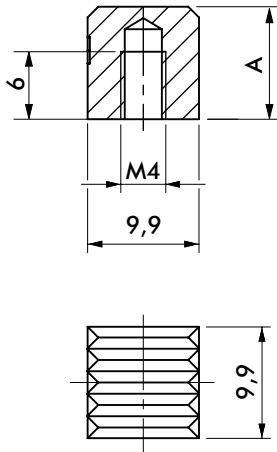

Hardened Steel Teeth	Part Number
Serrated	8JZ-049-1
Serrated	8JZ-027-1

Soft Steel Teeth	Part Number
Non-Serrated	8JZ-028-1

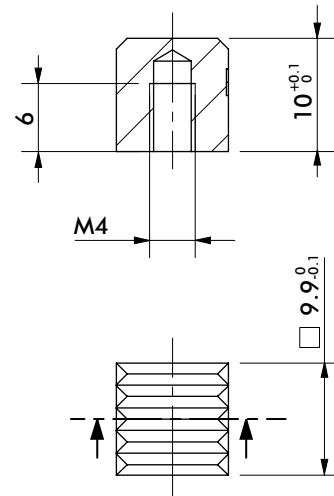
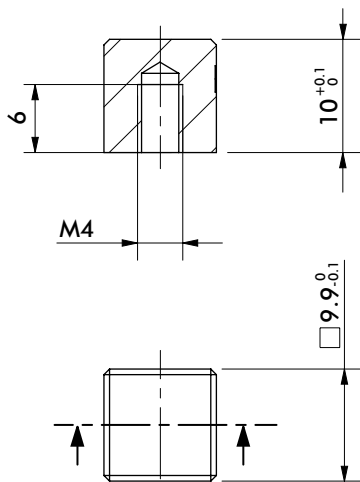

Hi-Temp Soft Steel Teeth	Part Number
Non-Serrated	8JZ-085-1

Hi-Temp Soft Steel Teeth	Part Number
Serrated	8JZ-092-1

84A2 SERIES ACCESSORIES

Cam Type Sheet Metal Grippers | Dimensions and Ordering Information

Plastic Teeth

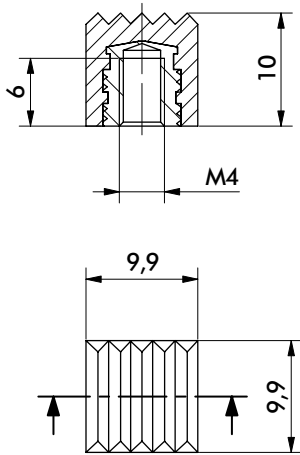

Steel Points

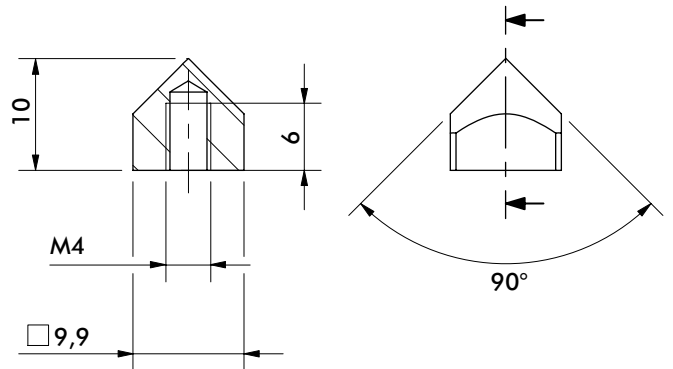
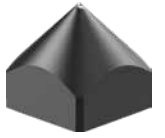

Plastic Teeth

90 Shore, Serrated

Part Number

8JZ-045-2

Hardened Steel Point

Pointed

Part Number

8JZ-029-1

Steel Points

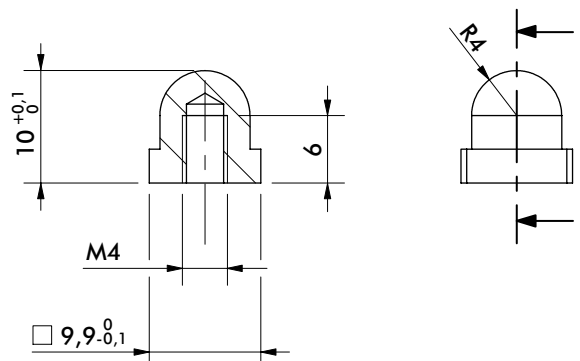
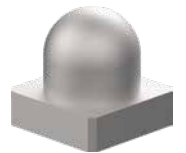
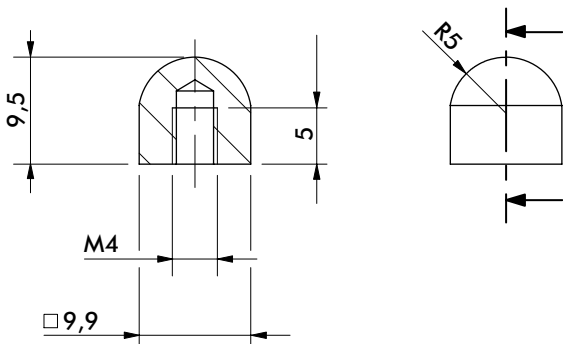

Hi-Temp Soft Steel Point

Rounded

Part Number

8JZ-074-1

Hi-Temp Soft Steel Point

Rounded

Part Number

8JZ-088-1

84A2 SERIES ACCESSORIES

Cam Type Sheet Metal Grippers | Dimensions and Ordering Information

Crown Teeth

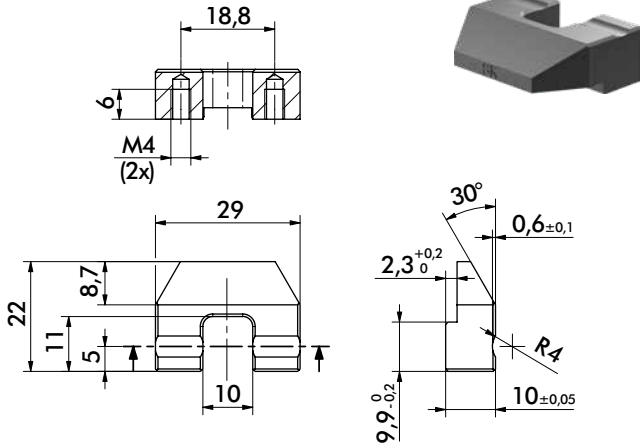

Hardened Steel Teeth

Part Number

Crown Lower

8JZ-036-2

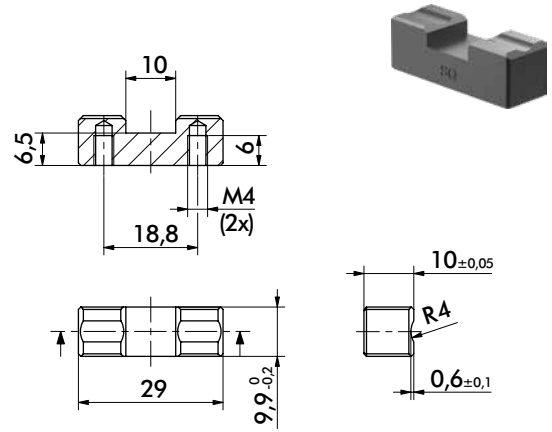

Hardened Steel Teeth

Part Number

Crown Lower

8JZ-051-1

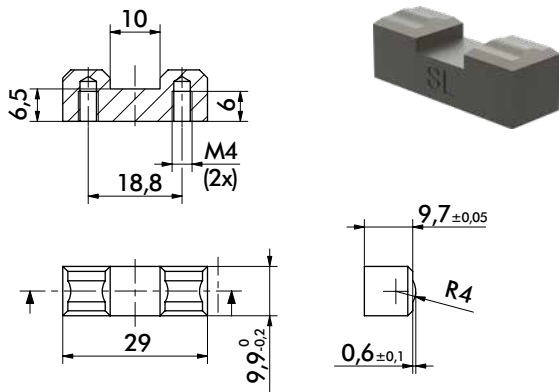

For material thickness 0,5 - 0,8 mm

Hardened Steel Teeth

Part Number

Crown Upper

8JZ-037-1

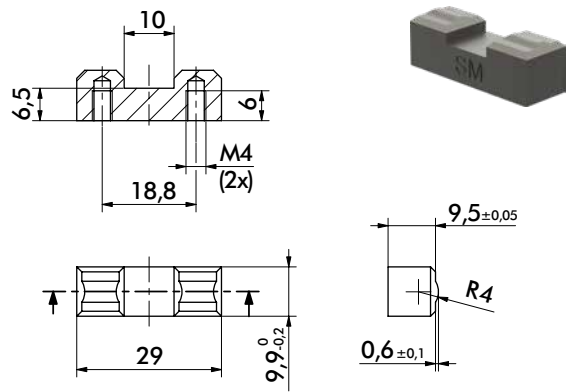

For material thickness 0,9 - 1,2 mm

Hardened Steel Teeth

Part Number

Crown Upper

8JZ-038-1

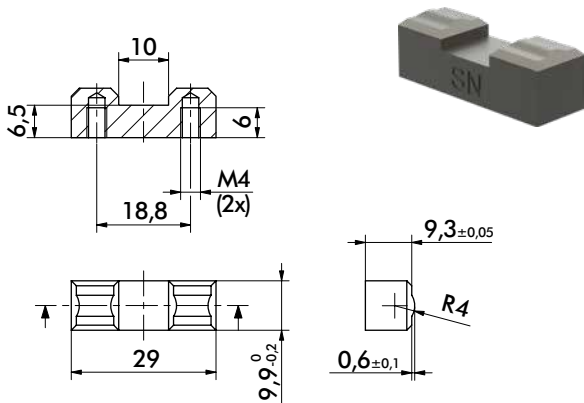

For material thickness 1,3 - 1,6 mm

Hardened Steel Teeth

Part Number

Crown Upper

8JZ-039-1

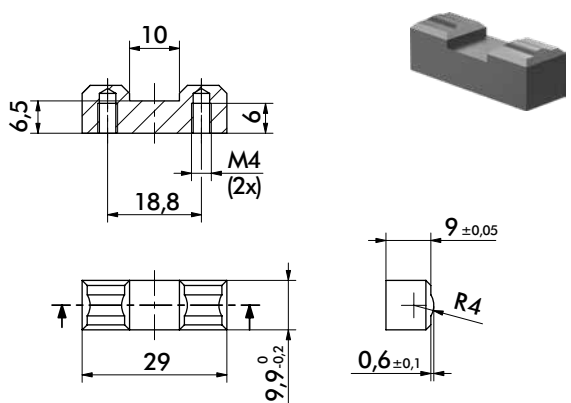

For material thickness 1,7 - 2,1 mm

Hardened Steel Teeth

Part Number

Crown Upper

8JZ-040-1

84A2 SERIES ACCESSORIES

Cam Type Sheet Metal Grippers | Dimensions and Ordering Information

Crown Teeth

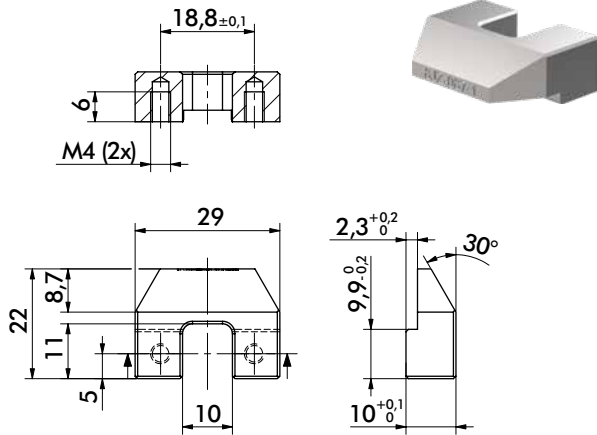

Hi-Temp Soft Steel Teeth Part Number **8JZ-087-1**
Crown Lower

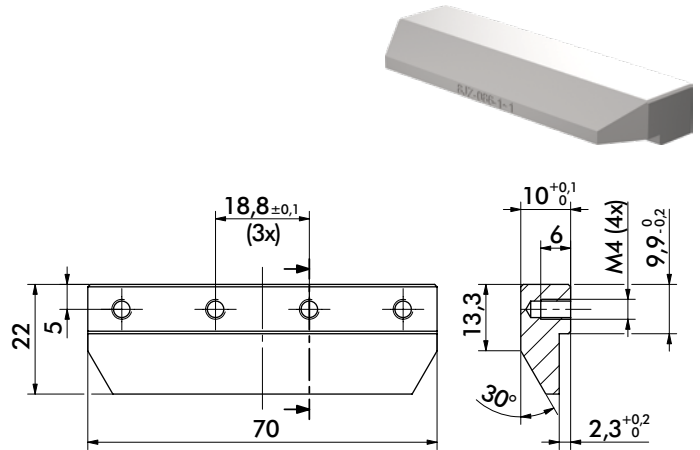

Hi-Temp Soft Steel Teeth Part Number **8JZ-086-1**
Crown Lower

Sensors

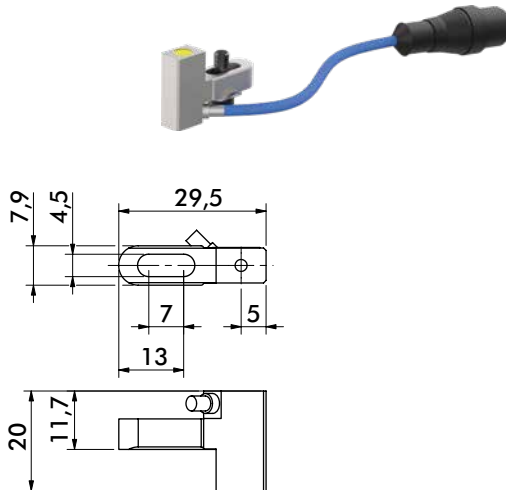

Part Present Sensor Part Number **8EA-087-1**
1.5mm Sensing Distance

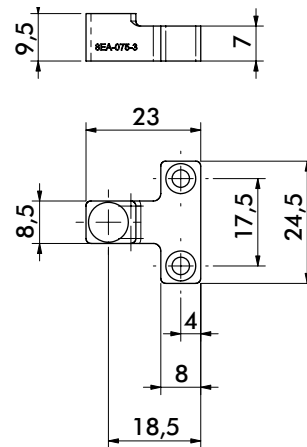

Part Present Sensor Part Number **8EA-075-2**
3mm Sensing Distance, 2m Cable
8EA-075-3
3mm Sensing Distance, M12X1

Sensors

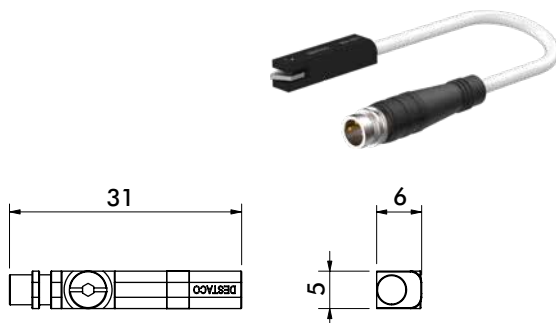

Proximity Switch Part Number **8EA-109-1**
T-Slot, M8x1 Plug

Mount

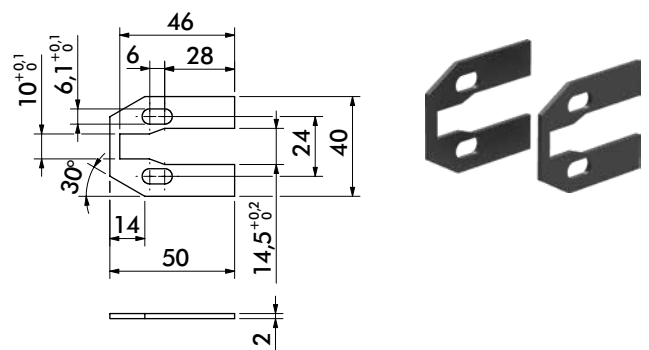

Mount Part Number **8MH-054-1**
Guards

84A2 SERIES ACCESSORIES

Cam Type Sheet Metal Grippers | Dimensions and Ordering Information

Mounts

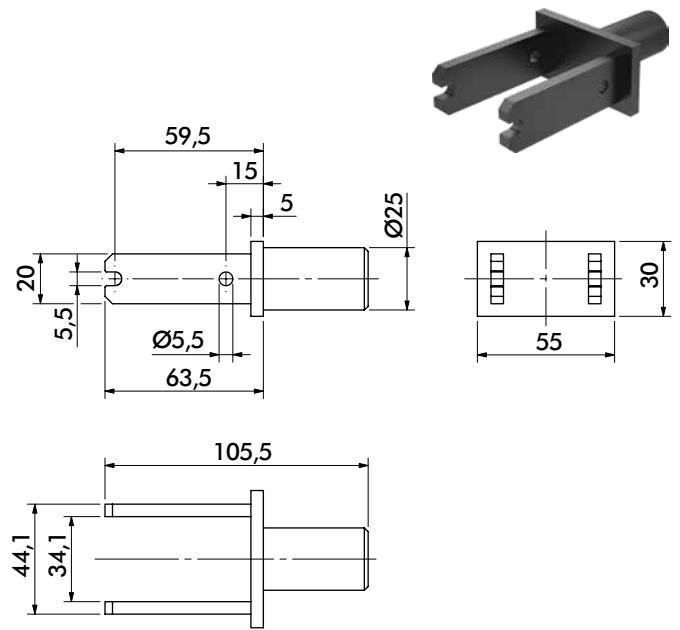
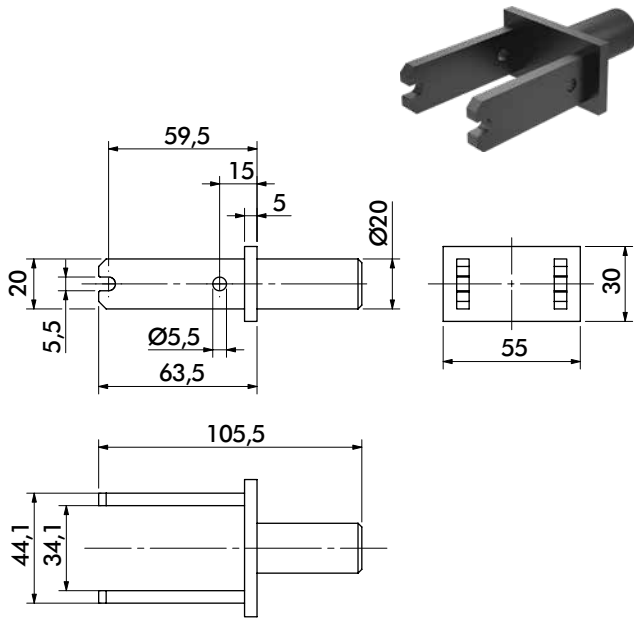

Mount **Part Number**
 Ø20mm Rear Rod **8MA-165-1**

Mount **Part Number**
 Ø25mm Rear Rod **8MA-166-1**

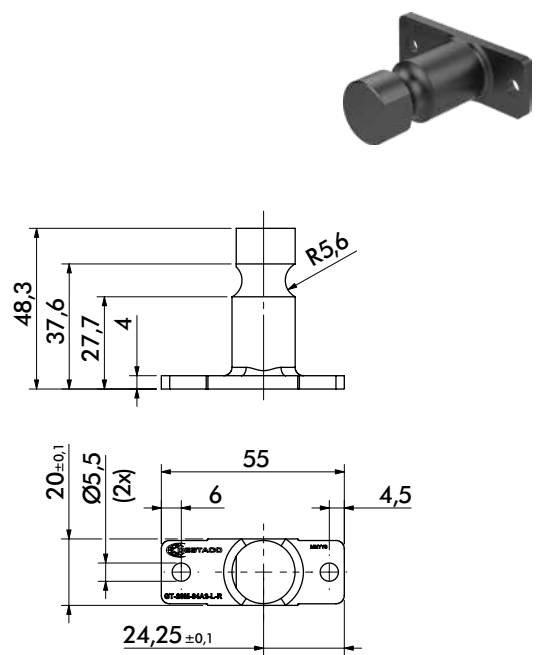
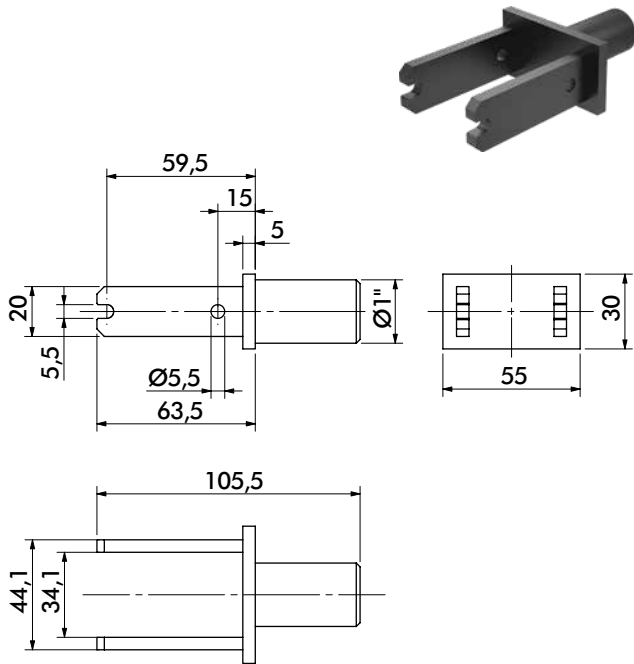

Mount **Part Number**
 Ø1.00" Rear Rod **8MA-168-1**

Mount **Part Number**
 Ø20mm Apple Core **GT-20M-84A2-L-R**

84A2 SERIES ACCESSORIES

Cam Type Sheet Metal Grippers | Dimensions and Ordering Information

Mounts

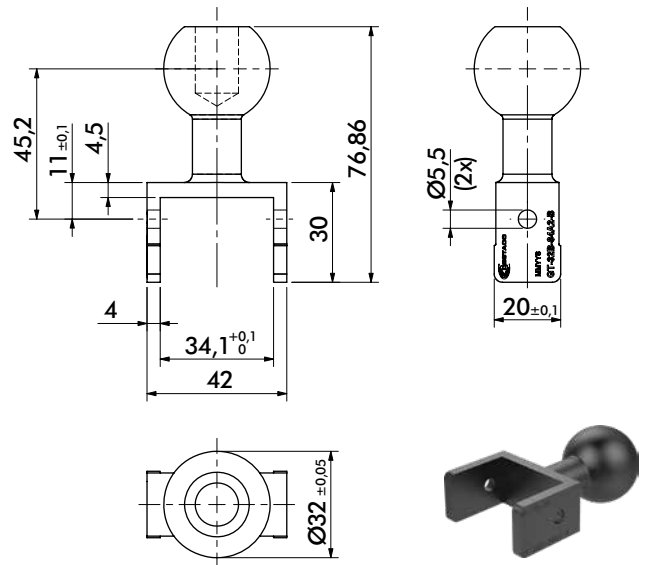
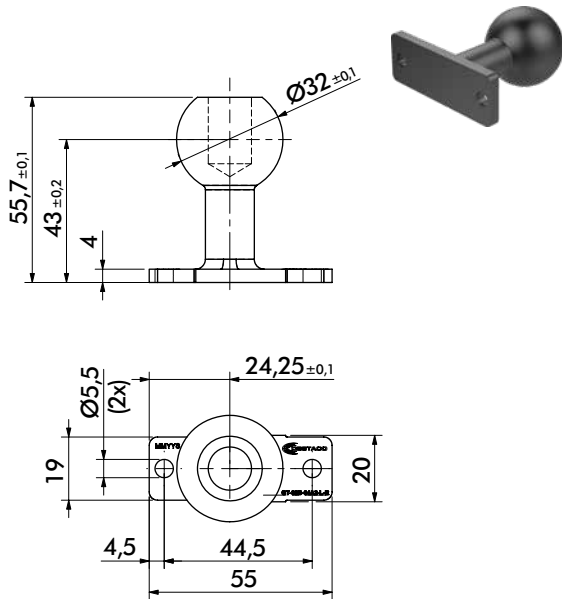

Mount

Ø32mm Rear Ball

Part Number

GT-32B-84A2-L-R

Mount

Ø32mm Flanged Ball

Part Number

GT-32B-84A2-B

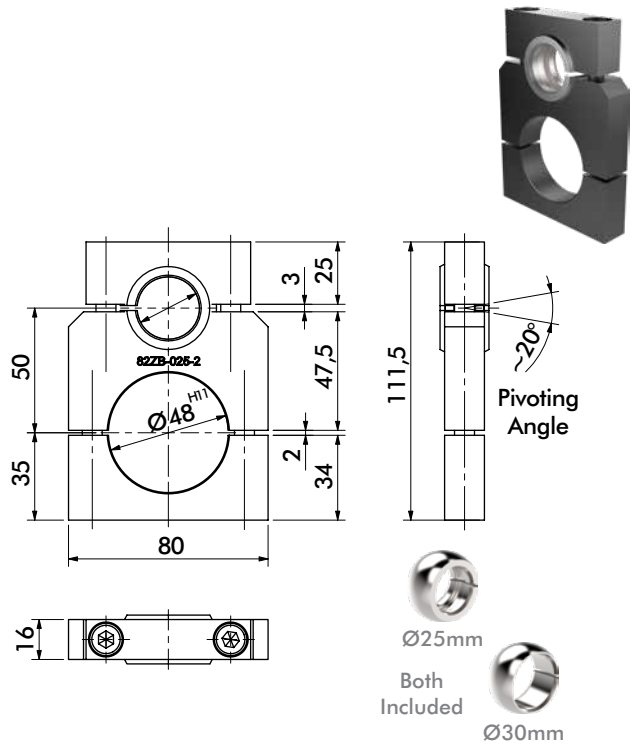
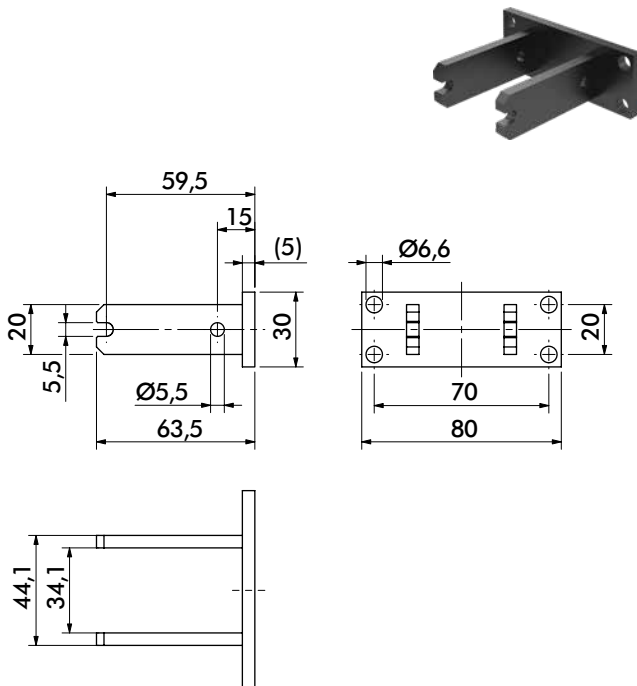

Mount

Rear Flange

Part Number

8MA-147-1

Mount

On-Body Swivel Ball

Part Number

82ZB-025-2